



空氣交絡噴嘴 JA-NAE Type False-Twist Texturing JA-NAE

JA-NAE 系列為組合式噴嘴，可根據需求選用適合的噴嘴芯片。

開放式噴嘴設計，操作簡易，進而強化工作效率及提升產品品質

提供高水準交絡性能且交絡點非常規則。

高效能的氣孔設計且有效降低耗氣量。

適用於各大廠牌的假撚變形機及空氣包覆機。

新型專利設計，徒手即可更換噴嘴芯，不需拆換工具。

This series of jet is supplied on the modular basis.
The ceramic insert can be substitute to meet different requirements.

Open type design. This makes yarn threading easy.
Also this can increase the efficiency and up-grade the quality of the products.

Provides high level of interlacing and very regular interlacing nodes.

High efficiency air hole design can reduce the air consumption.

Can apply in both DTY and ACY process.

The new patent design can be easily change jet insert by hand without tools

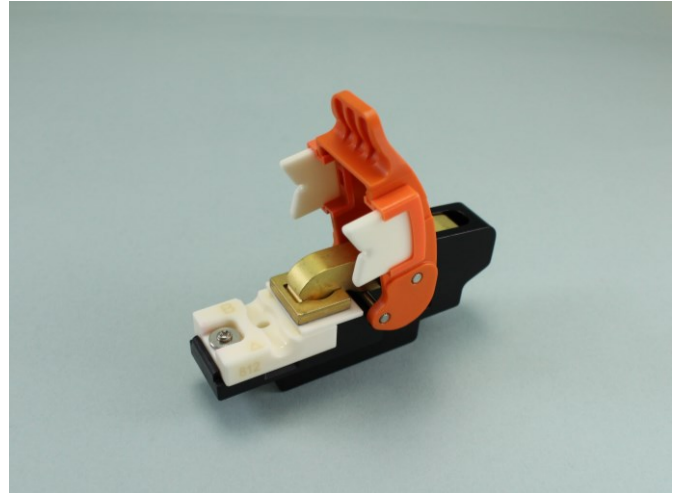

I. 噴嘴組件 Jet assembly

i. JA-NAE-T0-
 ↑
 Insert No.

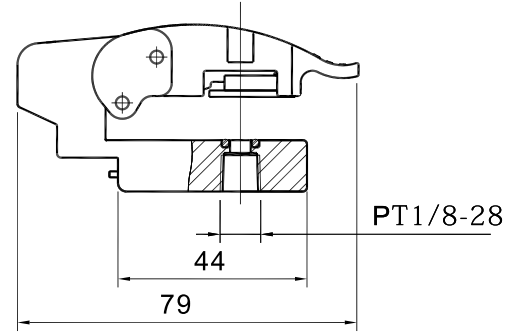
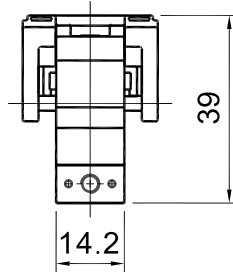
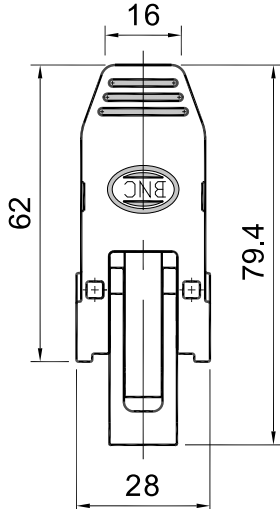

ii. JA-NAE-T1-
 ↑
 Insert No.

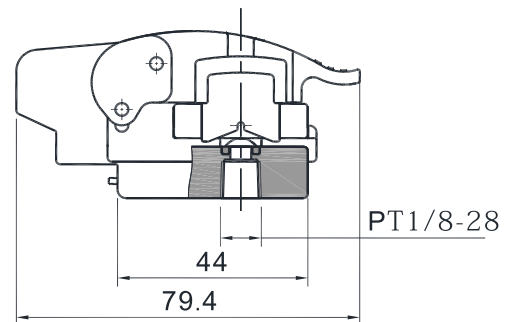
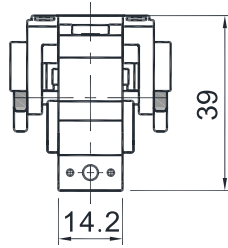
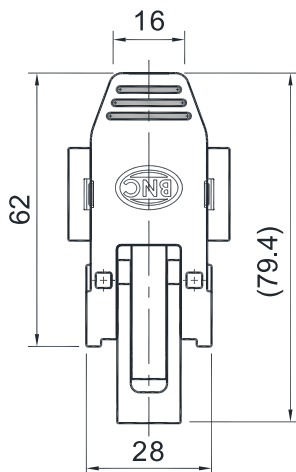

II. 噴嘴規格

Jet insert specifications

JA-
↑
Insert No.

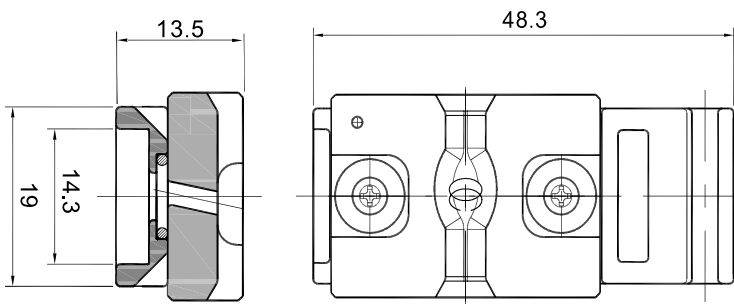

Jet insert	Air hole diameter(mm)	Air hole Shape	Count range Denier	Feature of interlacing Retention	Remark
JA-822A14	Ø 2.2	○	400~900	Strong	Triangle Channel with Vortex Chambe
JA-822A14-1	Ø 2.2	○	400~900	Strong	Triangle Channel with Vortex Chambe
JA-822N14	Ø 2.2	○	400~900	Strong	Triangle Channel with Vortex Chambe
JA-812	Ø 3.0	◌	800-1200	Strong	Vortex Chamber
JA-813	Ø 3.5	◌	1000~1500	Strong	Vortex Chamber

New Jet Set or New ceramic insert can be designed according to your special requirements.

II. 噴嘴空氣耗氣量

Jet air consumption

計算公式：

$$\text{耗氣量} = d^2 \times 0.46571 \times (p+1)$$

q_{vn} ：空氣消耗量 (m^3/h)

d ：噴嘴孔徑 (mm)

p ：使用的空氣壓力 (kg/cm^2)

Air consumption :

$$q_{vn} = d^2 \times 0.46571 \times (p+1)$$

q_{vn} ：Air consumption (m^3/h)

d ：Air hole diameter (mm)

p ：Air pressure (kg/cm^2)

對壓縮空氣的要求：

- 最大壓力波動 $\pm 0.1 kg/cm^2$
- 溫度(Tem) $25^\circ C \pm 5^\circ C$
- 相對濕度(RH%) $< 40\%$
- 最大含油率： $0.1mg/m^3$
- 最大殘餘微粒：
 - 顆粒大小 $1 \mu m$
 - 顆粒密度 $1mg/m^3$

Compressed air requirements

- Air pressure fluctuations max : $\pm 0.1 kg/cm^2$
- Temperature: $25^\circ C \pm 5^\circ C$
- Relative Humidity(RH%) $< 40\%$
- Max residual oil: $0.1mg/m^3$
- Max residual particles:
 - Particles size $1 \mu m$
 - Particles density $1mg/m^3$