



# 空氣交絡噴嘴 JA-NAF Type

## False-Twist Texturing Air Jet JA-NAF Type

JA-NAF 系列為組合式噴嘴，可根據需求選用適合的噴嘴芯片。

開放式噴嘴設計，操作簡易，進而強化工作效率及提升產品品質。

提供高水準交絡性能且交絡點非常規則。

高效能的氣孔設計且有效降低耗氣量。

新型專利設計，徒手即可更換噴嘴芯，不需拆換工具。

噴嘴芯在新舊噴嘴座皆可安裝使用。

新型專利的絲導穿孔設計，不累積污垢，延長清洗週期，提高加工紗品質及生產效率。

This series of jetis supplied on the modular basis.  
The ceramic insert can be substitute to meet different requirements.

Open type design. This makes yarn threading easy.  
Also this can increase the efficiency and up-grade the quality of the products.

Provides high level of interlacing and very regular interlacing nodes.

High efficiency air hole design can reduce the air consumption.

Can apply in both DTY and ACY process.

The new patent design can be easily change jet insert by hand without tools

Jet inserts can be applied to both new type and old type housings.

Our new designed ceramic guide (with a through hole) is under patent protection.

This “through hole” design guide can minimize the dirt accumulation caused by the through air. This can reduce the necessary cleaning time.

A clean ceramic guide in the assembly will improve the yarn quality and also increase the yarn production efficiency.



# I. 噴嘴組件

## Jet assembly

i. JA-NAF-T0-   
 ↑  
 Insert No.

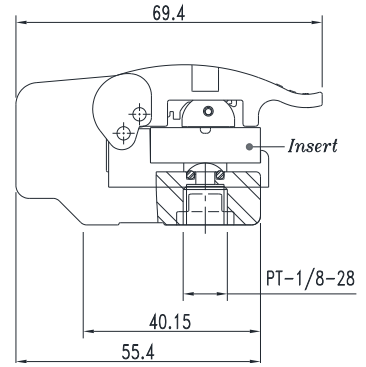
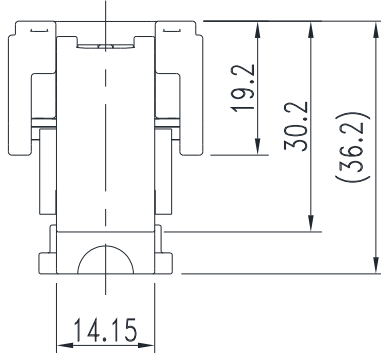
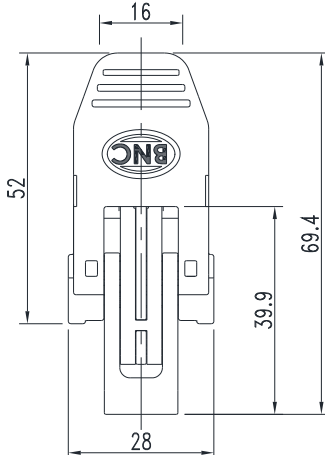

ii. JA-NAF-T1-   
 ↑  
 Insert No.

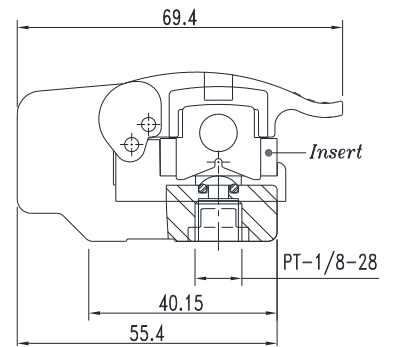
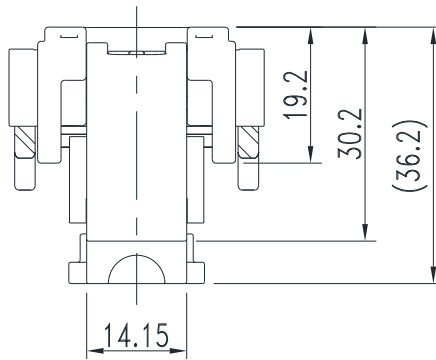
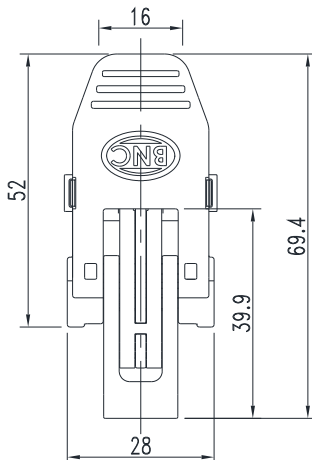

iii. JA-NAF-T2-   
 ↑  
 Insert No.

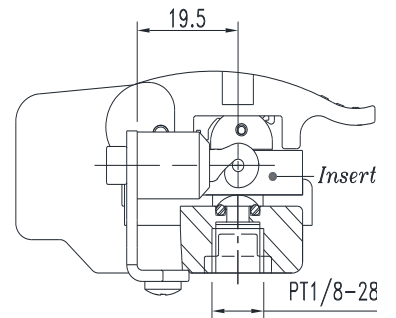
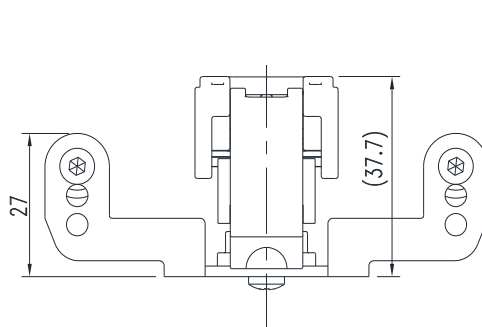
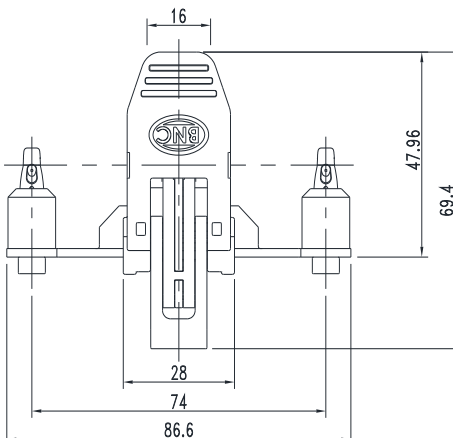







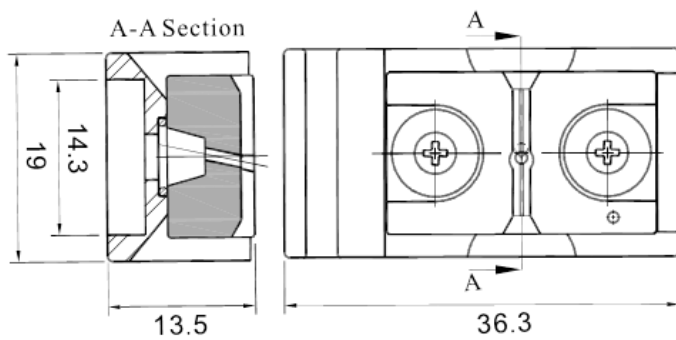





















## II. 噴嘴規格

### Jet insert specification

JA-  
↑  
Insert No.



Jet insert	Air hole diameter(mm)	Air hole Shape	Count range Denier	Feature of interlacing Retention	Remark
JA-101C-0.9N	∅ 0.9	○	20~75	Soft	C Type Channel
JA-102C-1.1N	∅ 1.1	○	50~125	Soft	C Type Channel
JA-102	∅ 1.1	○	50~125	Medium	
JA-103	∅ 1.2	○	75~150	Medium	
JA-202	∅ 1.4	○	125~300	Medium	
JA-203	∅ 1.4	○	125~300	Medium	
JA-204	∅ 1.6	○	200~450	Medium	
JA-205	∅ 1.2	○	75~150	Medium	
JA-331	∅ 2.2	○	400~900	Medium	
JA-S11R24	∅ 1.1	○	50~125	Strong	Triangle Channel with Vortex Chamber
JA-S14R40	∅ 1.4	○	125~300	Strong	Triangle Channel with Vortex Chamber
JA-S14R50	∅ 1.4	○	125~300	Strong	Triangle Channel with Vortex Chamber
JA-S14R60	∅ 1.4	○	125~300	Strong	Triangle Channel with Vortex Chamber
JA-123	∅ 1.2	○	75~150	Strong	Curved Channel
JA-221	∅ 1.4	◌	125~300	Strong	Curved Channel
JA-222	∅ 1.6	◌	175~450	Strong	Curved Channel

JA-223	∅ 1.6		175~450	Strong	Curved Channel
JA-226	∅ 1.8		225~650	Strong	Curved Channel
JA-227	∅ 2.0		300~750	Strong	Curved Channel
JA-072	∅ 0.9		20~75	Medium	Vortex Chamber
JA-073	∅ 1.0		30~100	Medium	Vortex Chamber
JA-172	∅ 1.1		50~125	Medium	Vortex Chamber
JA-162	∅ 1.1		50~125	Medium	Vortex Chamber
JA-163	∅ 1.2		75~150	Medium	Vortex Chamber
JA-263-4	∅ 1.4		125~300	Medium	Vortex Chamber
JA-264	∅ 1.6		175~450	Medium	Vortex Chamber
JA-266	∅ 1.8		225~650	Medium	Vortex Chamber
JA-267	∅ 2.0		300~750	Medium	Vortex Chamber
JA-013	∅ 1.1		50~125	Strong	Vortex Chamber
JA-111-A	∅ 1.1		50~125	Strong	Vortex Chamber
JA-112-A	∅ 1.2		75~150	Strong	Vortex Chamber
JA-113-A	∅ 1.3		100~250	Strong	Vortex Chamber
JA-114-A	∅ 1.4		125~300	Strong	Vortex Chamber
JA-212	∅ 1.4		125~300	Strong	Vortex Chamber
JA-213	∅ 1.6		175~450	Strong	Vortex Chamber
JA-214	∅ 1.8		225~650	Strong	Vortex Chamber
JA-312	∅ 2.0		300~750	Strong	Vortex Chamber
JA-412	∅ 2.5		600~1000	Strong	Vortex Chamber
JA-4121	∅ 2.0		300~750	Strong	Vortex Chamber
JA-4126	∅ 1.8		225~650	Strong	Vortex Chamber
JA-210	∅ 1.2		75~150	Soft	
JA-310	∅ 1.4		125~300	Soft	
JA-410	∅ 1.6		175~450	Soft	
JA-510	∅ 2.0		300~750	Soft	

Ceramic jet insert can be designed according to your special requirements.

## II. 噴嘴空氣耗氣量

### Jet air consumption

#### 計算公式：

$$\text{耗氣量} = d^2 \times 0.46571 \times (p+1)$$

$q_{vn}$ ：空氣消耗量 ( $m^3/h$ )

$d$ ：噴嘴孔徑 (mm)

$p$ ：使用的空氣壓力 ( $kg/cm^2$ )

#### Air consumption：

$$q_{vn} = d^2 \times 0.46571 \times (p+1)$$

$q_{vn}$ ：Air consumption ( $m^3/h$ )

$d$ ：Air hole diameter (mm)

$p$ ：Air pressure ( $kg/cm^2$ )

#### 對壓縮空氣的要求：

- 最大壓力波動  $\pm 0.1 kg/cm^2$
- 溫度(Tem)  $25^\circ C \pm 5^\circ C$
- 相對濕度(RH%)  $< 40\%$
- 最大含油率： $0.1mg/m^3$
- 最大殘餘微粒：
  - 顆粒大小  $1 \mu m$
  - 顆粒密度  $1mg/m^3$

#### Compressed air requirements

- Air pressure fluctuations max： $\pm 0.1 kg/cm^2$
- Temperature:  $25^\circ C \pm 5^\circ C$
- Relative Humidity(RH%)  $< 40\%$
- Max residual oil:  $0.1mg/m^3$
- Max residual particles:
  - Particles size  $1 \mu m$
  - Particles density  $1mg/m^3$